

# TB 9-6695-301-50

## DEPARTMENT OF THE ARMY TECHNICAL BULLETIN

### CALIBRATION PROCEDURE FOR TORQUE CELLS, MIS-26485, TYPE I (LEBOW, MODEL 2133 SERIES), TORQUE CELL MIS-26485 TYPE II CLASS I (LEBOW, MODEL 2351-102), LOAD CELLS, MIS-26331 (AMETEK AEROSPACE MODEL USP1 SERIES), AND TOROID CORP., MODEL 35-133BCF60K, (MIS-26331TY4), AND FORCE/TORQUE INDICATOR MGCPLUS (13589298)

Headquarters, Department of the Army, Washington, DC

15 May 2003

*Approved for public release; distribution is unlimited*

#### REPORTING OF ERRORS AND RECOMMENDING IMPROVEMENTS

You can improve this manual. If you find any mistakes or if you know of a way to improve these procedures, please let us know. Mail your letter, DA Form 2028 (Recommended Changes to Publications and Blank Forms) directly to Commander, U.S. Army Aviation and Missile Command, ATTN: AMSAM-MMC-MA-NP, Redstone Arsenal, AL 35898-5000. A reply will be furnished to you. You may also provide DA Form 2028 information to AMCOM via e-mail, fax, or the World Wide Web. Our FAX number is: DSN 788-6546 or Commercial 256-842-6546. Our e-mail address is: [2028@redstone.army.mil](mailto:2028@redstone.army.mil). Instructions for sending an electronic 2028 may be found at the back of this procedure. For the World Wide Web, use: <https://amcom2028.redstone.army.mil>.

SECTION		Paragraph	Page
	I. IDENTIFICATION AND DESCRIPTION		
	Test instrument identification .....	1	2
	Forms, records, and reports .....	2	2
	Calibration description .....	3	2
	II. EQUIPMENT REQUIREMENTS		
	Equipment required .....	4	3
	Accessories required .....	5	3
	III. CALIBRATION PROCESS		
	Preliminary instructions .....	6	4
	Equipment setup .....	7	6
	Torque cell .....	8	7
	2500FTLB torque cell .....	9	8
	Load cell compression and tension .....	10	10
	Final procedure .....	11	15

**SECTION I  
IDENTIFICATION AND DESCRIPTION**

**1. Test Instrument Identification.** This bulletin provides instructions for the calibration of Torque Cells, MIS-26485, Type I (Lebow, Model 2133 Series), Torque Cell MIS-26485 Type II class I (Lebow, Model 2351-102) Load Cells, MIS-26331 (Ametek Aerospace Model USP1 Series), and Toroid Corp., Model 35-133BCF60K, (MIS-26331TY4), and Force/Torque Indicator MGCPlus (13589298) . The manufacturer's manual was used as the prime data source in compiling these instructions. The equipment being calibrated, torque and load cells with force/torque indicator MGCPlus (13589298) will be referred to as the TI (test instrument) throughout this bulletin.

**a. Model Variations.** None.

**b. Time and Technique.** The time required for this calibration is approximately 10 hours, using the physical technique.

**2. Forms, Records, and Reports**

**a.** Forms, records and reports required for calibration personnel at all levels are prescribed by TB 750-25.

**b.** Adjustments to be reported are designated (R) at the end of the sentence in which they appear. When adjustments are in tables, the (R) follows the designated adjustment. Report only those adjustments made and designated with (R).

**3. Calibration Description.** TI parameters and performance specifications which pertain to this calibration are listed in table 1.

Table 1. Calibration Description

Test instrument parameters	Performance specifications
Force/torque indicator	Torque Range: $\pm 0.1$ -3.06 mV/V Accuracy: $\pm 0.03\%$ indication  Force Range: $\pm 0.1$ -3.06 mV/V Accuracy: $\pm 0.0025\%$ of Full scale
Torque cells <sup>1</sup>	Range: 0 to 5 ft-lbs (0 to 60 in-lbs) 0 to 20 ft-lbs (0 to 240 in-lbs) 0 to 100 ft-lbs (1200 in-lbs) 0 to 500 ft-lbs (10 to 6000 in-lbs) 0 to 1000 ft-lbs (0 to 12,000 in-lbs) Accuracy: $\pm 0.5\%$ of applied torque from 20% FS to FS $\pm 0.5\%$ of 20% FS below 20% Range: 0 to 2500 ft-lbs Accuracy: $\pm 0.5\%$ of applied torque or 2.5 ft-lbs, whichever is greater

See footnote at end of table.

Table 1. Calibration Description - Continued

Test instrument parameters	Performance specifications
Load cells	Range: 0 to 2000 lbs 0 to 5000 lbs 0 to 20,000 lbs 0 to 60,000 lbs Accuracy: ±0.25% of reading from 10% of FS to FS

<sup>1</sup>Torque cells with range not specifically listed in table 1 may be calibrated, using the appropriate procedure and applicable range limits listed in table 3. Accuracy must conform to the applicable accuracy listed in table 1.

## SECTION II EQUIPMENT REQUIREMENTS

**4. Equipment Required.** Table 2 identifies the specific equipment to be used in this calibration procedure. This equipment is issued with Secondary Reference Calibration Standard Set. Alternate items may be used by the calibrating activity. The items selected must be verified to perform satisfactorily prior to use and must bear evidence of current calibration. The equipment must meet or exceed the minimum use specifications listed in table 2. The accuracies listed in table 2 provide a four-to-one ratio between the standard and TI. Where the four-to-one ratio cannot be met, the actual accuracy of the equipment selected is shown in parenthesis.

**5. Accessories Required.** Common usage accessories are not listed in this calibration procedure. Peculiar accessories required are: Transfer Load Cell Calibration Spreadsheet (TLCCS.xls) and the MGCplus Assistant software.

Common name	Minimum use specifications	Manufacturer and model (part number)
LOAD CELL	Range: 0 to 2000 lbs 0 to 5000 lbs 0 to 20,000 lbs 0 to 60,000 lbs Accuracy: ±0.0625% of reading from 10% of full-scale to full-scale. (Accuracy: ±0.1% of reading from 10% of full-scale to full-scale.)	Revere Corp., Model USP1-2B (MIS-26331TY1); USP1-5B (MIS-26331TY2) USP1-20B (MIS-26331TY3), and Toroid Corp., Model 35-133BCF60K (MIS-26331TY4)
LOAD CELL INDICATOR	Range: ±0.1-3.06 mV/V Accuracy: .0001 mV/V	DMP40S2
TORQUE CALIBRATION KIT NO. 1	Range: 0 to 60 in-lb (0 to 5 ft-lb) (0 to 960 in-oz) Effective length of 2.5-in. hex drive to 1/4-in. male square adapter Accuracy: ±0.25% of load	CDI, Model 60 STPI (7915975)

**TB 9-6695-301-50**

Table 2. Minimum Specifications of Equipment Required - Continued

Common name	Minimum use specifications	Manufacturer and model (part number)
TORQUE CALIBRATION KIT NO. 2	Range: 50 to 2000 in-lb (4.17 to 1656.67 ft-lb) Effective length of 10-in. with 1/2-in. square drive, double male adapter Accuracy: $\pm 0.25\%$ of load	CDI, Model 2000 STPI (7915976)
TORQUE CALIBRATION KIT NO. 3	Range: 150 to 1000 ft-lb Effective length of 40-in. with 1-in. square drive, double male adapter Accuracy: $\pm 0.25\%$ of load	CDI, Model 1000 STPF (7915977)
TORQUE CELL	Range: 0 to 2500 ft-lbs Accuracy: $\pm 0.125\%$ of applied torque (20 to 100% of range) or 0.6 ft-lbs whichever is greater ( $\pm 0.25\%$ of applied torque)	Lebow, Model 2351-102 (MIS-26485 Type II Class I) with Force/torque indicator, Model MGCPlus (13589298)
TORQUE WRENCH	Range: 0 to 2500 ft-lbs	Power-Dyne, Model PD-2501 (PD-2501)
WEIGHT SET	Range: 1 to 300 lb Accuracy: Class T	(7915978)

**SECTION III  
CALIBRATION PROCESS**

**6. Preliminary Instructions**

**a.** The instructions outlined in paragraphs **6** and **7** are preparatory to the calibration -process Personnel should become familiar with the entire bulletin before beginning the calibration.

**b.** Items of equipment used in this procedure are referenced within the text by common name as listed in table 2.

**c.** Unless otherwise specified, verify the result of each test and, whenever the test requirement is not met, take corrective action before continuing with the calibration. Adjustments required to calibrate the TI are included in this procedure. Additional maintenance information is contained in the manufacturer's manual for this TI.

**WARNING**

HIGH VOLTAGE is used or exposed during the performance of this calibration. DEATH ON CONTACT may result if personnel fail to observe safety precautions.

**CAUTION**

When operating with low range torque cells (TI), apply full load slowly and cautiously to prevent damage.

- d.** Unless otherwise specified all controls and control settings refer to the TI.

**TB 9-6695-301-50**

**7. Equipment Setup**

**a.** Verify TI is clean and free from defects that would impair its operation.

**b.** Allow equipment to stabilize to ambient temperature.

**c.** Prepare a worksheet similar to table 3 (table 3 may be reproduced for this purpose). Calculate torque for cardinal points listed in table 4 for each TI. Use CALCULATED TORQUE formula shown after table 3.

**NOTE**

If the arm lengths are correct to: (.02-in. for 40-in. arm); (.005-in. for 10-in. arm); and (.0015-in. for 2.5-in. arm); then nominal values may be used for length and the equation becomes:

$$T = \text{Nominal length} \times \text{weight corrected for local gravity.}$$

**d.** Enter actual weight, calculated torque, and tolerances on worksheet.

Table 3. Torque Calibration Chart

Test instrument range	Torque calibrator	Weight (lbs)	Actual weight <sup>1</sup> (lbs)	Calculated <sup>2</sup> torque	Tolerance range	
					Min (-0.5%)	Max (+0.5%)
0 to 60 in-lb 0 to 5 ft-lb	Model		<b>lbs</b>			
	60 STPI	5				
	(2.5-in. radius)	10				
		15				
		20				
Full scale	24					
0 to 20 ft-lb 0 to 240 in-lb	Model		<b>lbs</b>			
	2000 STPI	5				
	(10-in. radius)	10				
		15				
		20				
Full scale	24					
0 to 100 ft-lb 0 to 1200 in-lb	Model		<b>lbs</b>			
	2000 STPI	24				
	(10-in. radius)	48				
		72				
		96				
Full scale	120					
0 to 500 ft-lb	Model		<b>lbs</b>			
	STPI	30				
	(40-in. radius)	60				
		90				
		120				
Full scale	150					

See footnotes at end of table.

**TB 9-6695-301-50**

Table 3. Torque Calibration Chart - Continued

Test instrument range	Torque calibrator	Weight (lbs)	Actual weight <sup>1</sup> (lbs)	Calculated <sup>2</sup> torque	Tolerance range	
					Min (-0.5%)	Max (+0.5%)
0 to 1000 ft-lb	Model		<b>lbs</b>			
	STPI	60				
	(40-IN. radius)	120				
		180				
		240				
	Full scale	300				

<sup>1</sup>Actual weight = Mass (in pounds) x G/980.665. Where: G is local gravity and 980.665 cm/sec<sup>2</sup> is standard gravity.

<sup>2</sup>Calculated torque (T) = Actual Length x Actual Weight

**e.** Install torque cell holding fixture on a sturdy work bench and secure with bolts.

**f.** Insert male end of TI torque cell into holding fixture with electrical connector pointing in an approximately 7 o'clock position (5 o'clock for ccw torque). Connect TI indicator to torque cell and to 115 V ac power source. Turn power switch to on and allow 30 minutes for unit to warm up.

**NOTE**





It is important that cell be installed in this way to ensure that the torque cell is calibrated in the same orientation that it is be used.





**g.** Install appropriate torque calibration arm with weight hanger and adapters supplied with kit

**NOTE**

Position of arm must be such that load cable hangs from circular portion of arm; in case of 40 in. arm, proper position is from near horizontal to about 10 degrees upward slope.

**h.** Press the **CHANNEL** +and - keys to select channel **3**.

**i.** Press the **F4** key on the TI indicator until you see the   soft keys. Press the   soft keys as necessary to select the torque cell entry for the TI and direction being calibrated.

**j.** Press the **SIGNAL**     to select the **GROSS** mode of operation. Press the **F4** key on the TI indicator until you see the **Acal** soft key. Press the **Acal** soft key as necessary to activate the **Acal** enunciator.

**k.** Press the **F4** key on the TI indicator until you see the **UNIT** soft key. Press the **UNIT** soft key as necessary to select the appropriate units to display.



**l.** Press the **F4** key on the TI indicator until you see →**0**← soft key. Press the ® **0**← soft key to zero force/torque indicator.

**m.** Exercise system in direction of intended calibration. Apply full load to system, using appropriate weights from weight sets. Decrease load slowly and carefully, hesitating about 30 seconds at full and no-load positions. Repeat the cycle twice.

**NOTE**

System should be exercised by loading to full load in the proper direction just prior to calibration.

**CAUTION**

Do not exceed rated capacity of TI.

**NOTE**

Readings are + (plus) in cw direction and - (minus) in ccw.

**8. Torque Cell**

**a. Performance Check**

(1) Press the **F4** key on the TI indicator until you see →**0**← soft key. Press the ® **0**← soft key to zero force/torque indicator.

**NOTE**

Calibration data on TI should be taken within 30 minutes after exercising.

**NOTE**

Apply torque smoothly in the increasing torque direction.

(2) Apply weights from weight sets to weight hanger of torque calibration kit to obtain torque in cw direction for each calibration point listed in table 3. Remove weights. If TI indication is not within tolerances listed in table 3 then perform **b** below.

**NOTE**

Deenergize TI indicator before changing torque cells.

(3) Repeat **7f** through **8a(2)** above for all torque cells in both cw and ccw directions.

**b. Adjustments**

**NOTE**

If necessary to update device setup, connect a serial cable between the computer com port and the TI indicator com port and use the MGCplus Assistant software to load the correct device file for the size and direction of the TI torque cell being calibrated. Add the serial number to the device name.

**TB 9-6695-301-50**

- (1) Press the **SET** button and then press the **F3** key to select the **Amplifier** menu.
- (2) Press the **←** key to select **Transducer** from **Amplifier** menu.
- (3) Press the **SIGNAL ▲▼◀▶** and **←** keys to ensure that the **Transducer** menu is set according to (a) thru (d) below.
  - (a) Type: Full bridge – low level.
  - (b) Excitation: 5 V
  - (c) Unit: ftlb (inlb for 5FTLB cell) mV/V
  - (d) K-Factor: 0.0000
- (4) Press the **SIGNAL ▲▼◀▶** and **←** keys to select **measure....** (left hand side of screen)
- (5) With no weights applied press the **SIGNAL ▲▼◀▶** and **←** keys to select **measure** for **Point 1**.
- (6) Apply weight for an approximate full scale torque (table 3). Press the **SIGNAL ▲▼◀▶** and **←** keys to select **measure** for **Point 2**.
- (7) Press the **SIGNAL ▲▼◀▶** and **←** keys and key-pad under the **ftlb** column for **Point 2**. Input the calculated torque from table 3.
- (8) Press the **SIGNAL ▲▼◀▶** and **←** keys to select **OK**.
- (9) Press the **SIGNAL ▲▼◀▶** and **←** keys to select **Adjust amplifier**. Press the **ESC** key.
- (10) Press the **SET** key. On the **Save set-up?** menu, select **Yes** by pressing the **←** key.
- (11) Repeat **8a** above; if indications are not within tolerance then torque cell is bad.

**9. 2500FTLB Torque Cell**

**a. Performance Check**

- (1) Position mounting plate on a stable and rigid work surface and secure with bolts or clamps.
- (2) Assemble TI torque cell, extension, standard torque cell, and torque wrench on mounting plate. Ensure that locating pins of both torque cells and extension are engaged in their respective mounting holes. Install torque wrench crank handle in socket.
- (3) Connect TI torque cell and standard torque cell to their respective indicators.

**NOTE**

The torque applied by torque wrench (ccw, for example) produces opposite torque (cw) in both torque cells.

- (4) Press the **F4** key on the TI indicator until you see the **↕** **↕** soft keys. Press the **↕** **↕** soft keys as necessary to select the torque cell entry for the TI and direction being calibrated.

(5) Press the **F4** key on the TI indicator until you see the **UNIT** soft key. Press the **UNIT** soft key as necessary to select the appropriate units to display.

(6) Press the **F4** key on the TI indicator until you see →**0**← soft key. Press the **0**← soft key to zero TI indicator.

**NOTE**

Exercise torque cells by loading to full load (2500 ft-lbs) in the proper direction (cw or ccw) and just prior to calibration.

**CAUTION**

Do not exceed 2500 ft-lbs.

(7) Apply 2500 ft-lbs torque with the torque wrench, then decrease slowly and carefully, hesitating about 30 seconds at full and no-load positions. Repeat cycle twice or until 0 setting is stable.

(8) Observe that operation is smooth and that both indicators show essentially the same load. Both indicators should indicate a plus (+) sign in the cw direction and a minus (-) sign in the ccw direction.

(9) Remove all load (torque) from TI. (Remove torque wrench if necessary)

(10) Press the **F4** key on the TI indicator until you see →**0**← soft key. Press the **0**← soft key to zero force/torque indicator.

(11) Operate crank handle of torque wrench in the direction exercised to obtain load cell indicator indication shown in table 4. If TI indicator indications are not within limits specified, perform **b** below.

Table 4. Calibration Points

Standard (torque cell) (ft-lbs)	Test instrument (ft-lbs)	
	Min	Max
300	297.5	302.5
400	397.5	402.5
600	597	603
800	796	804
1000	995	1005
1500	1492.5	1507.5
2000	1990	2010
Full scale 2500	2487.5	2512.5

(12) Repeat **6** through **11** above in the opposite direction.

**TB 9-6695-301-50**

**b. Adjustments**

**NOTE**

If necessary to update device setup, connect a serial cable between the computer com port and the TI indicator com port and use the MGCplus Assistant software to load the correct device file for the size and direction of the TI torque cell being calibrated. Add the serial number to the device name.

- (1) Press the **SET** button and then press **F3** key to select the **Amplifier** menu.
- (2) Press the **←** key to select **Transducer** from **Amplifier** menu.
- (3) Press the **SIGNAL ▲▼ ◀▶** and **←** keys to ensure that the **Transducer** menu is set according to (a) thru (d) below.
  - (a) Type: Full bridge – low level.
  - (b) Excitation: 5 V
  - (c) Unit: ftlb (inlb for 5FTLB cell) mV/V
  - (d) K-Factor: 0.0000
- (4) Press the **SIGNAL ▲▼ ◀▶** and **←** keys to select **measure....** (left hand side of screen).
- (5) With no torque applied press the **SIGNAL ▲▼ ◀▶** and **←** keys to select **measure** for **Point 1**.
- (6) Apply torque for an approximate full scale torque (table 4). Press the **SIGNAL ▲▼ ◀▶** and **←** keys to select **measure** for **Point 2**.
- (7) Press the **SIGNAL ▲▼ ◀▶** and **←** keys and key-pad under the **ftlb** column for **Point 2**. Input the load cell indicator indication.
- (8) Press the **SIGNAL ▲▼ ◀▶** and **←** keys to select **OK**.
- (9) Press the **SIGNAL ▲▼ ◀▶** and **←** keys to select **Adjust amplifier**. Press the **ESC** key.
- (10) Press the **SET** key. On the **Save set-up?** menu select **Yes** by pressing the **←** key.
- (11) Repeat **a** above. If indications are not within tolerance then torque cell is bad.

**10. Load Cell Compression and Tension**

**a. Performance Check**

- (1) Connect equipment as shown in figure 1 (figure 2 for tension), using appropriate standard load cell for range of TI load cell being calibrated.

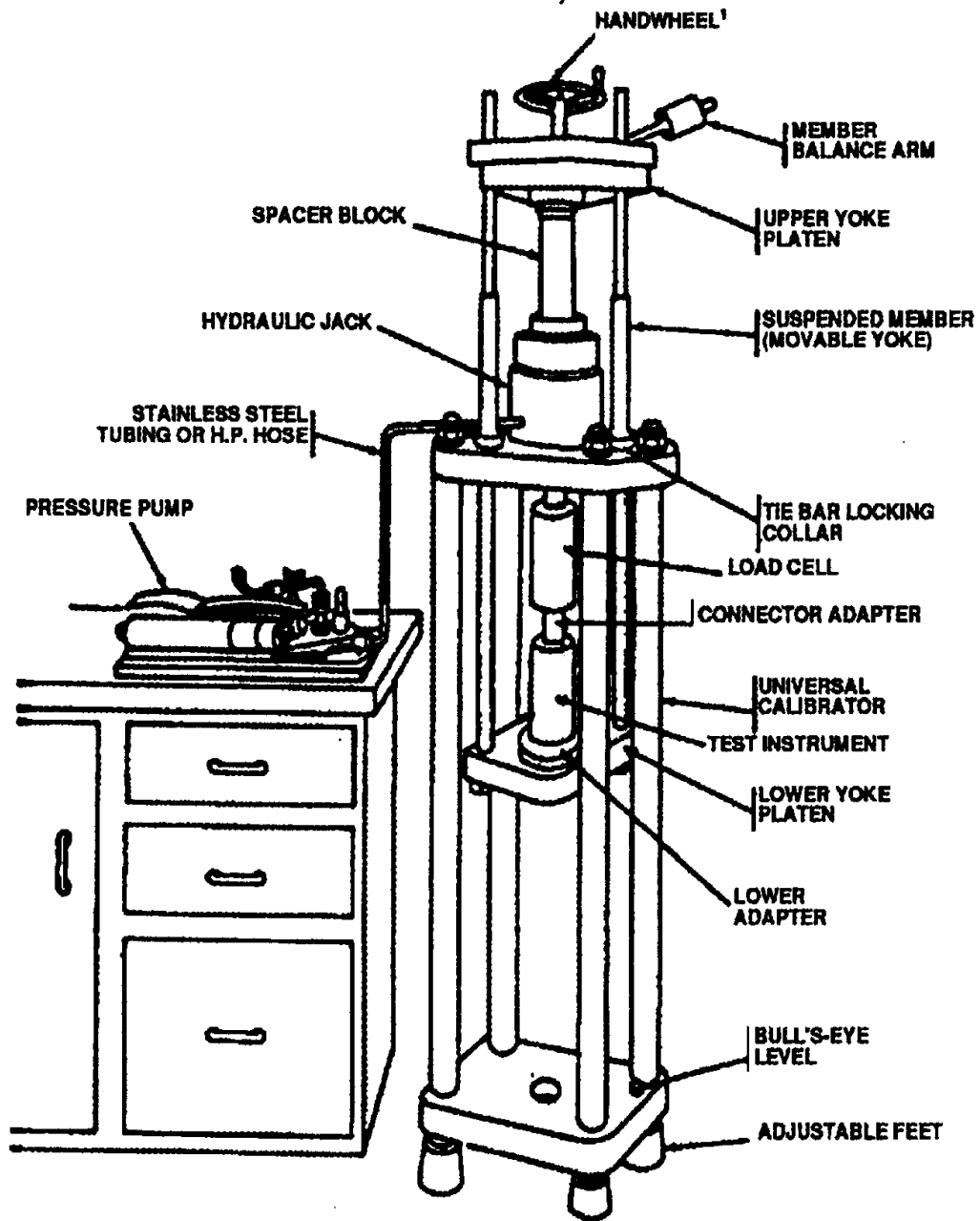

<sup>1</sup>ON SOME MODELS OF CALIBRATOR, THE HANDWHEEL IS REPLACED BY AN ELECTRIC MOTOR

Figure 1. Load cell compression check - equipment setup.

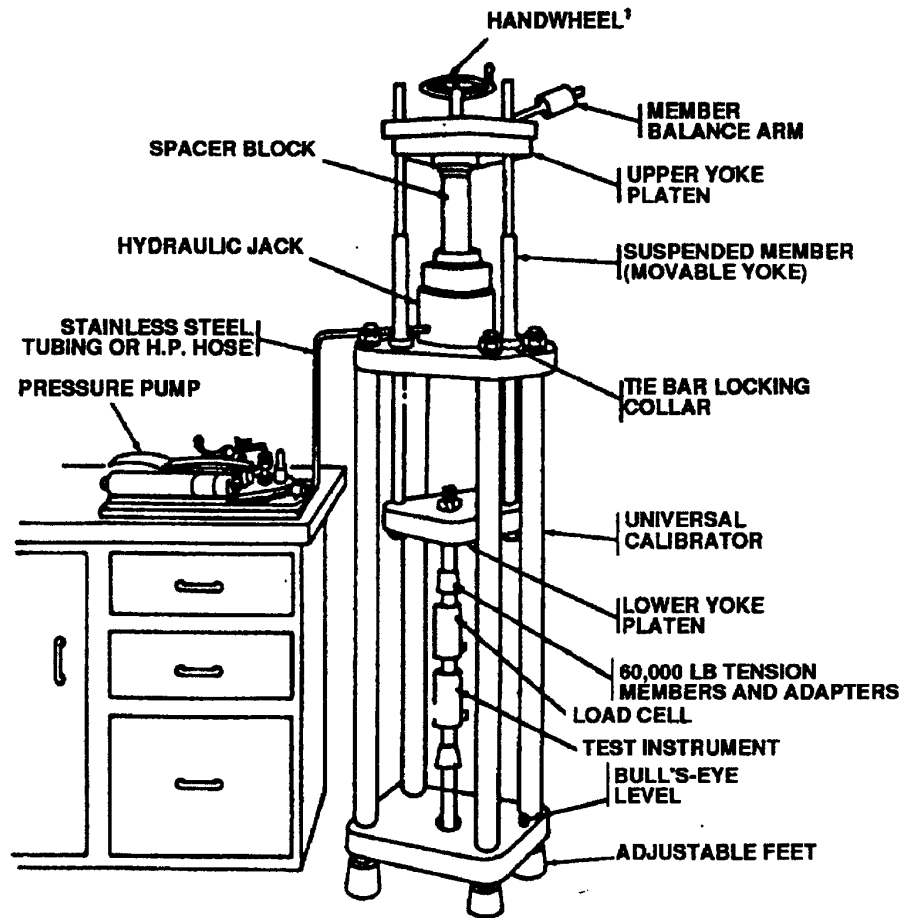

<sup>1</sup>ON SOME MODELS OF CALIBRATOR, THE HANDWHEEL IS REPLACED BY AN ELECTRIC MOTOR

Figure 2. Load cell tension check - equipment setup.

(2) Place a mild steel pad on top of load button of standard load cell. Use tension members and adapters as needed.









**CAUTION**

Do not exceed range of standard load cell or TI load cell.

**NOTE**



Zero out tare weight of all suspended items (tension).

(3) Connect standard load cell indicator to standard load cell and TI indicator to TI load cell. Connect power cables to 115 V ac power source. Energize all equipment and allow 15 minute warm up.

- (4) Press the TI indicator **CHANNEL** + and - keys to select channel **1**.
- (5) Press the **F4** key on the TI indicator until you see the   soft keys. Press the   soft keys as necessary to select the load cell entry for the TI load cell and direction being calibrated.
- (6) Press the **SIGNAL**     keys to select the **GROSS** mode of operation. Press the **F4** key on the TI indicator until you see the **Acal** soft key. Press the **Acal** soft key as necessary to activate the **Acal** enunciator.
- (7) Press the **F4** key on the TI indicator until you see the **UNIT** soft key. Press the **UNIT** soft key as necessary to select **lb** to be displayed.
- (8) Exercise TI load cell and standard load cell as described in (a) through (c) below:

**CAUTION**

Do not overload standard load cell or TI load cell.

- (a) Apply force slowly to capacity of TI load cell.
  - (b) Release force slowly to obtain minimum indication on force/torque indicator.
  - (c) Repeat (a) and (b) above two more times.
- (9) With no load applied press the **F4** key on the TI indicator until you see  **0** soft key. Press the  **0** soft key to zero force/torque indicator. Zero should be stable within 0.02 percent of capacity. Zero the load cell indicator.
  - (10) Apply force to obtain a load cell indicator indication equivalent to approximately 10 percent of maximum range of TI load cell. TI indicator should indicate within  $\pm 25\%$  of load cell indicator reading. If TI indicator indications are not within  $\pm 25\%$  of load cell indicator reading then perform **b** below.
  - (11) Repeat (10) above for TI load cell cardinal points of 20, 40, 60, 80 and 100% of full scale. Release force.
  - (12) Rotate TI load cell 120°.
  - (13) Repeat (5) and (12) above for a total of three runs.
  - (12) Repeat (5) through (13) above for tension calibration.
  - (13) Repeat (5) through (13) above for all TI load cells.

**b. Adjustments**

**NOTE**

If necessary to update device setup, connect a serial cable between the computer com port and the TI indicator com port and use the MGCplus Assistant software to load the correct device file for the size and direction of the TI load cell being calibrated. Add the serial number to the device name.

**TB 9-6695-301-50**

(1) Press the **F4** key on the TI indicator until you see the **UNIT** soft key. Press the **UNIT** soft key as necessary to select mV/V units to be displayed. Press the **SET** key then press the **F3** key to select the **Amplifier** menu. Press the **SIGNAL ▲▼◀▶** and **←** keys to select **Display** from the **Amplifier** menu. Press the **SIGNAL ▲▼◀▶** and **←** keys to key-pad set the decimal places to **6**.

(2) Zero the load cell indicator.

(3) Apply force for load cell indicator indications listed in the Applied Force column of the Transfer Load Cell Calibration Spreadsheet (TLCCS.xls) for the TI load cell and direction being calibrated. Enter TI indicator readings in the Transfer Load Cell Calibration Spreadsheet (TLCCS.xls) for the TI load cell being calibrated.

(4) Rotate TI load cell 120°.

(5) Repeat (1) and (4) above for a total of three runs.

(6) Repeat **b(1)** thru (5) above for tension. If the TLCCS.xls indicates a passing condition (after all entries are made) then continue to next step. If the TLCCS.xls indicates a failing condition then TI load cell is bad.

(7) Press the **SET** button and then press the **F3** key to select the **Amplifier** menu.

(8) Press the **←** key to select **Transducer** from **Amplifier** menu.

(9) Press the **SIGNAL ▲▼◀▶** and **←** keys to ensure that the **Transducer** menu is set according to (a) thru (d) below.

- (a) Type: SG full bridge.
- (b) Excitation: 5V
- (c) Unit: lb mV/V
- (d) Zero point: 0.000 0.00000
- (e) Nom.-value: (TI nominal full scale) 3.00000
- (f) K-Factor: 0.0000

(10) Press the **SIGNAL ▲▼◀▶** and **←** keys to select **Ext. fct...**

(11) Press the **SIGNAL ▲▼◀▶** and **←** keys and key-pad input the C0-C3 coefficients from the TLCCS.xls.

(12) Press the **SIGNAL ▲▼◀▶** and **←** keys to select **OK**.

(13) Press the **SIGNAL ▲▼◀▶** and **←** keys to select **Adjust amplifier**. Press the **ESC** key.

(14) Press the **F3** key to select the **Amplifier** menu. Press the **SIGNAL ▲▼◀▶** and **←** keys to select **Display** from the **Amplifier** menu. Press the **SIGNAL ▲▼◀▶** and **←** keys and key-pad set the decimal places to **2**. Press the **ESC** key.

(15) Press the **SET** key. On the **Save set-up?** menu select **Yes** by pressing the **←** key.

(16) Repeat **10a.** above; if indications are not within tolerance, then TI load cell is bad.





**11. Final Procedure**

- a.** Deenergize and disconnect all equipment.
- b.** Annotate and affix DA label/form in accordance with TB 750-25.
- c.** If all TI Load and Torque cells are not calibrated with the indicator then affix a DA Label 163 Limited Use.

**TB 9-6695-301-50**

By Order of the Secretary of the Army:

**ERIC K. SHINSEKI**  
*General, United States Army*  
*Chief of Staff*

**OFFICIAL:**

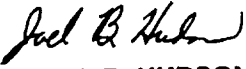
  
**JOEL B. HUDSON**  
*Administrative Assistant to the*  
*Secretary of the Army*

0309703

Distribution:

To be distributed in accordance with STD IDS No. RLC-1500, 2 January 2003, requirements for calibration procedure TB 9-6695-301-50.

**Instructions for Submitting an Electronic 2028**

The following format must be used if submitting an electronic 2028. The subject line must be exactly the same and all fields must be included; however, only the following fields are mandatory: 1, 3, 4, 5, 6, 7, 8, 9, 10, 13, 15, 16, 17, and 27.

From: "Whomever" [whomever@redstone.army.mil](mailto:whomever@redstone.army.mil)

To: <2028@redstone.army.mil

Subject: DA Form 2028

1. **From:** Joe Smith
2. Unit: home
3. **Address:** 4300 Park
4. **City:** Hometown
5. **St:** MO
6. **Zip:** 77777
7. **Date Sent:** 19-OCT -93
8. **Pub no:** 55-2840-229-23
9. **Pub Title:** TM
10. **Publication Date:** 04-JUL-85
11. Change Number: 7
12. Submitter Rank: MSG
13. **Submitter FName:** Joe
14. Submitter MName: T
15. **Submitter LName:** Smith
16. **Submitter Phone:** 123-123-1234
17. **Problem:** 1
18. Page: 2
19. Paragraph: 3
20. Line: 4
21. NSN: 5
22. Reference: 6
23. Figure: 7
24. Table: 8
25. Item: 9
26. Total: 123
27. **Text**

This is the text for the problem below line 27.

